

Model: ENERGY
ET44

SPECIFICATIONS:

| | |
|---------------|--------------|
| Year of Intro | 2000 |
| Thrust | 44LBS |
| Volts | 12VDC |
| Amp Draw | 0 to 48 amps |
| Mount | 09 Transom |
| Speeds | 5/2 |

PARTS ORDERING & TECH ASSISTANCE

MotorGuide Consumer Relations
 Phone 918-831-6989
 Fax 800-982-8093

Returned Goods must be accompanied with a Returned Goods Authorization. Contact MotorGuide Consumer Relations to obtain RGA.

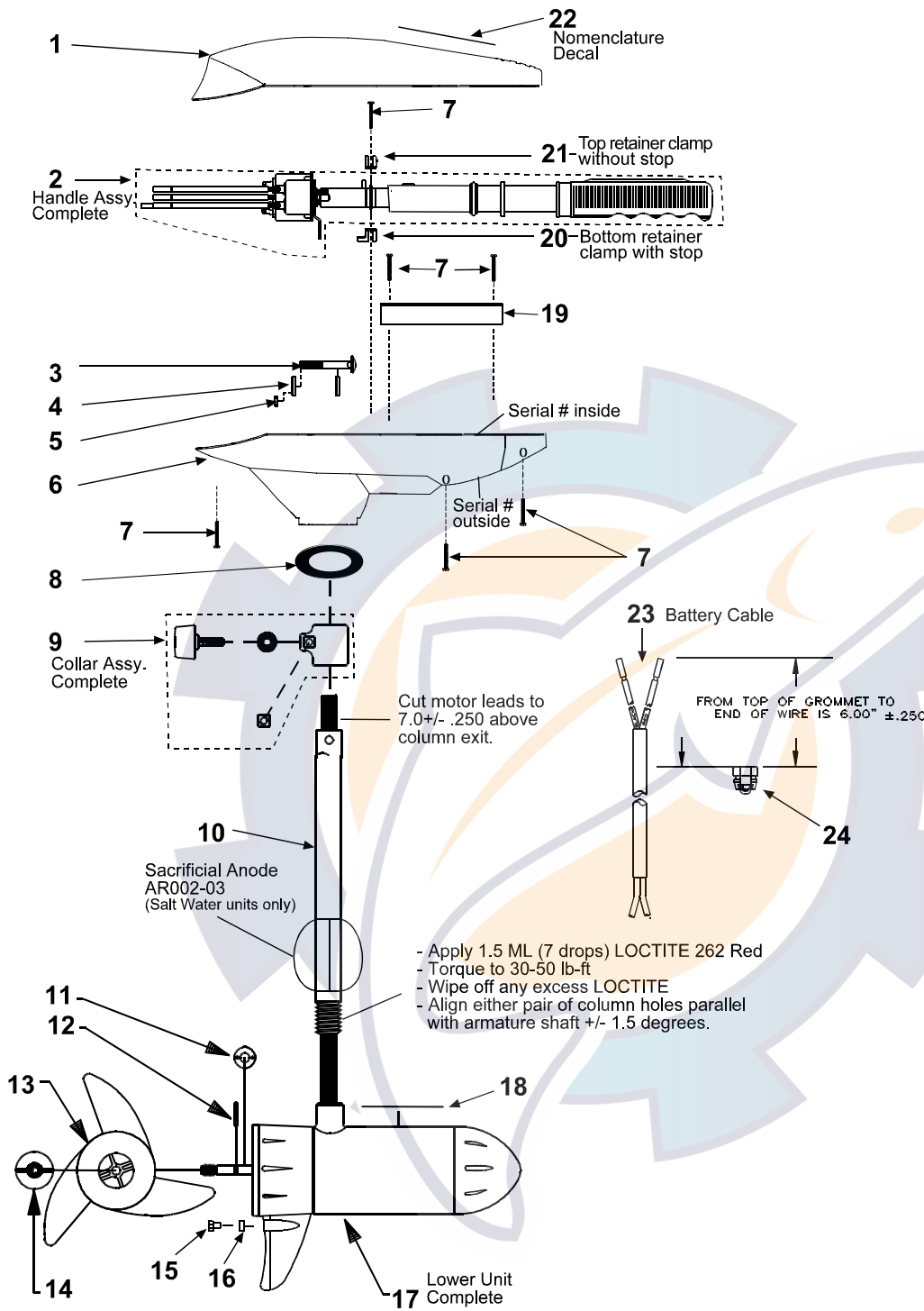

| KEY | DESCRIPTION | PART # | KEY | DESCRIPTION | PART # | KEY | DESCRIPTION | PART # |
|-----|-------------------------|----------|-----|----------------|----------|-----|-------------------------------|----------|
| 1 | TOP HOUSING COVER BLACK | ET053-17 | 10 | COLUMN 36" | TT049-05 | 16 | ANODE (Saltwater models only) | AR002-02 |
| 2 | HANDLE ASY | BT372-09 | 11 | COLUMN 42" | TT049-06 | 17 | MOTOR | ET397-03 |
| 3 | BOLT | TT134-02 | 12 | COLUMN 50" | FR049-13 | 18 | LOWER UNIT DECAL | ET060-08 |
| 4 | CURVED WASHER | TT171-08 | 13 | PROP DRIVE PIN | AR175-01 | 19 | CABLE PLATE | AT155-06 |
| 5 | NYLON LOCK NUT | XT098-02 | 14 | PROP/3 BLADE | BR102-01 | 20 | BOTTOM RETAINER CLAMP | AR036-05 |
| 6 | T/H BASE BLACK | ET004-16 | 15 | PROP/2 BLADE | AF124-12 | 21 | UPPER RETAINER CLAMP | AR036-04 |
| 7 | #8 X 5/8 SCREW | AT141-01 | | | AF124-07 | 22 | NOMENCLATURE DECAL | AT056-22 |
| 8 | COLUMN SEAL | AT079-01 | | | AR099-01 | 23 | BATTERY CABLE | XT328-06 |
| 9 | DEPTH ADJUSTMENT COLLAR | AR158-01 | | | DK133-01 | 24 | GROMMET | GR019-01 |

LOWER UNIT BREAKDOWN

Model:
ET44

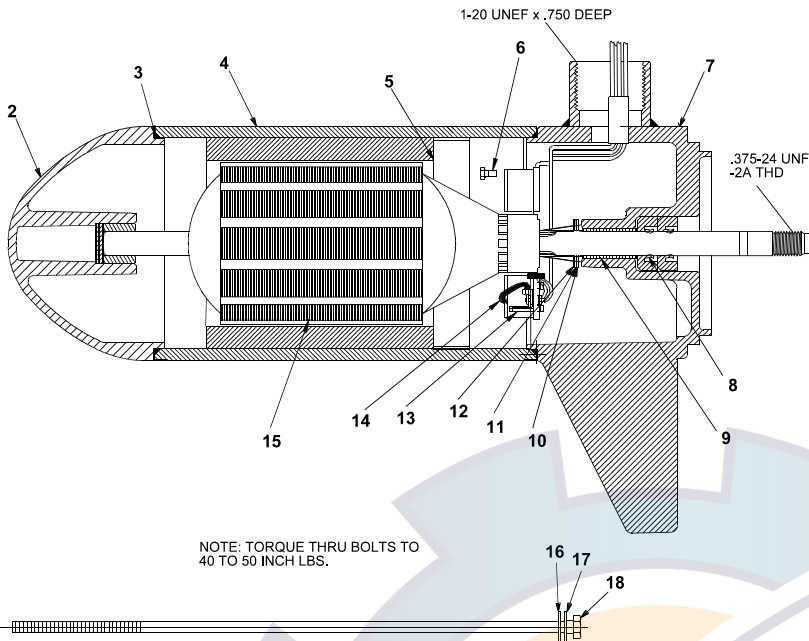

| KEY | QTY | DESCRIPTION | PART NO. |
|-----|-----|-----------------------|-----------|
| 1 | X | MOTOR | ET397-03 |
| 2 | 1 | NOSE CAP | XF3212-01 |
| 3 | 2 | O RING SEAL | MR217-01 |
| 4 | 1 | HOUSING ASY | ET3210-01 |
| 5 | 1 | RETAINER | JF233-01 |
| 6 | 2 | BRUSH CARD SCREW | MR228-01 |
| 7 | 1 | COMM CAP | PF3205-03 |
| 8 | 2 | SHAFT SEAL | MR223-01 |
| 9 | 1 | BEARING | MR206-01 |
| 10 | 1 | NYLATRON WASHER | MR226-01 |
| 11 | 1 | WASHER | MR227-01 |
| 12 | 1 | E RING | MR219-01 |
| 13 | 2 | BRUSH SPRINGS | MR214-02 |
| 14 | 1 | BRUSH ASY LESS SPRING | DF3201-01 |
| 15 | 1 | ARMATURE | KF3207-01 |
| 16 | 4 | STATIC SEAL | MR222-01 |
| 17 | 4 | THRU BOLT WASHER | MR216-02 |
| 18 | 2 | THRU BOLT | MR218-01 |

WIRING

